



## **Enterprise 2.0:**

**Nuova collaborazione, comunicazione unificata e business.**

**Rischi e opportunità per le imprese**

**Annamaria Di Ruscio**



***21 aprile 2008***



# Il contesto che ci vede attori

# Economia della simbiosi

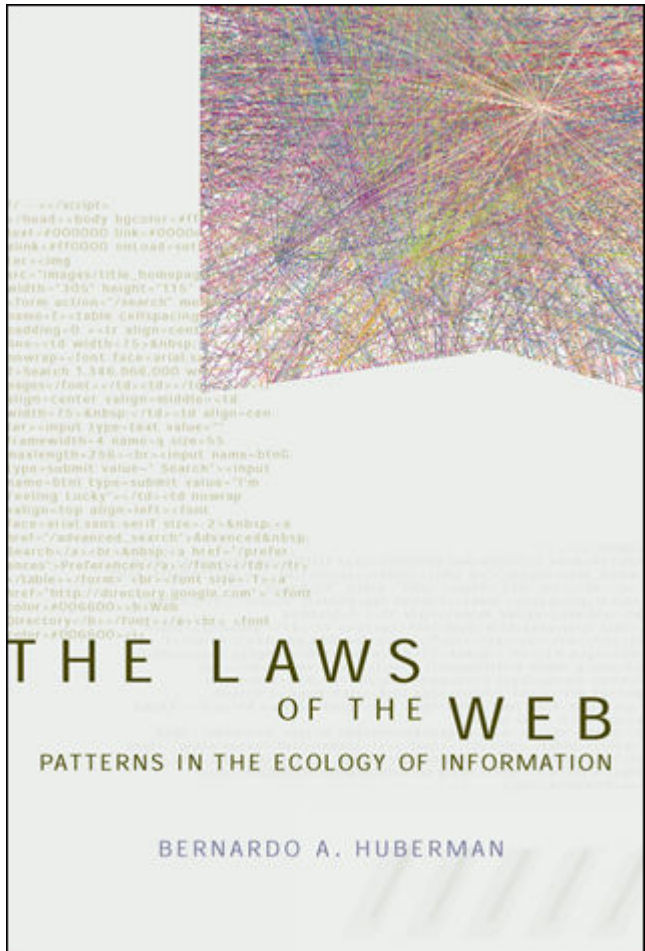

Rewriting the Rules of Culture and Commerce

# THE LONG TAIL

'Read this brilliant and timely book if you want to get a look at the future of business'  
ERIC SCHMIDT, CEO GOOGLE



How Endless Choice is  
Creating Unlimited Demand

CHRIS ANDERSON

# The Web 2.0 Mind Map

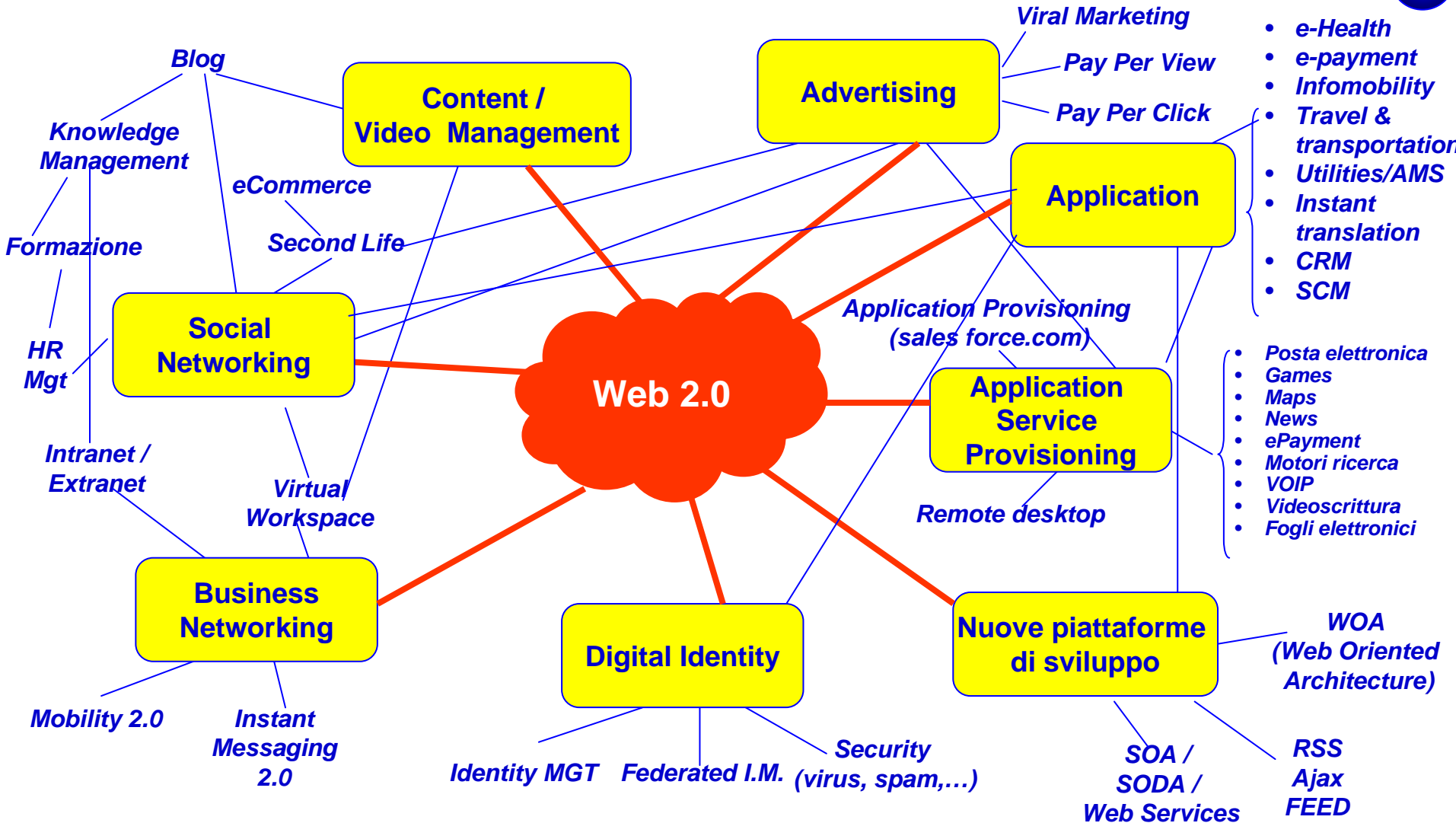

Fonte: NetConsulting, settembre 2007

# Web 2.0: quali finalità...

% risposte

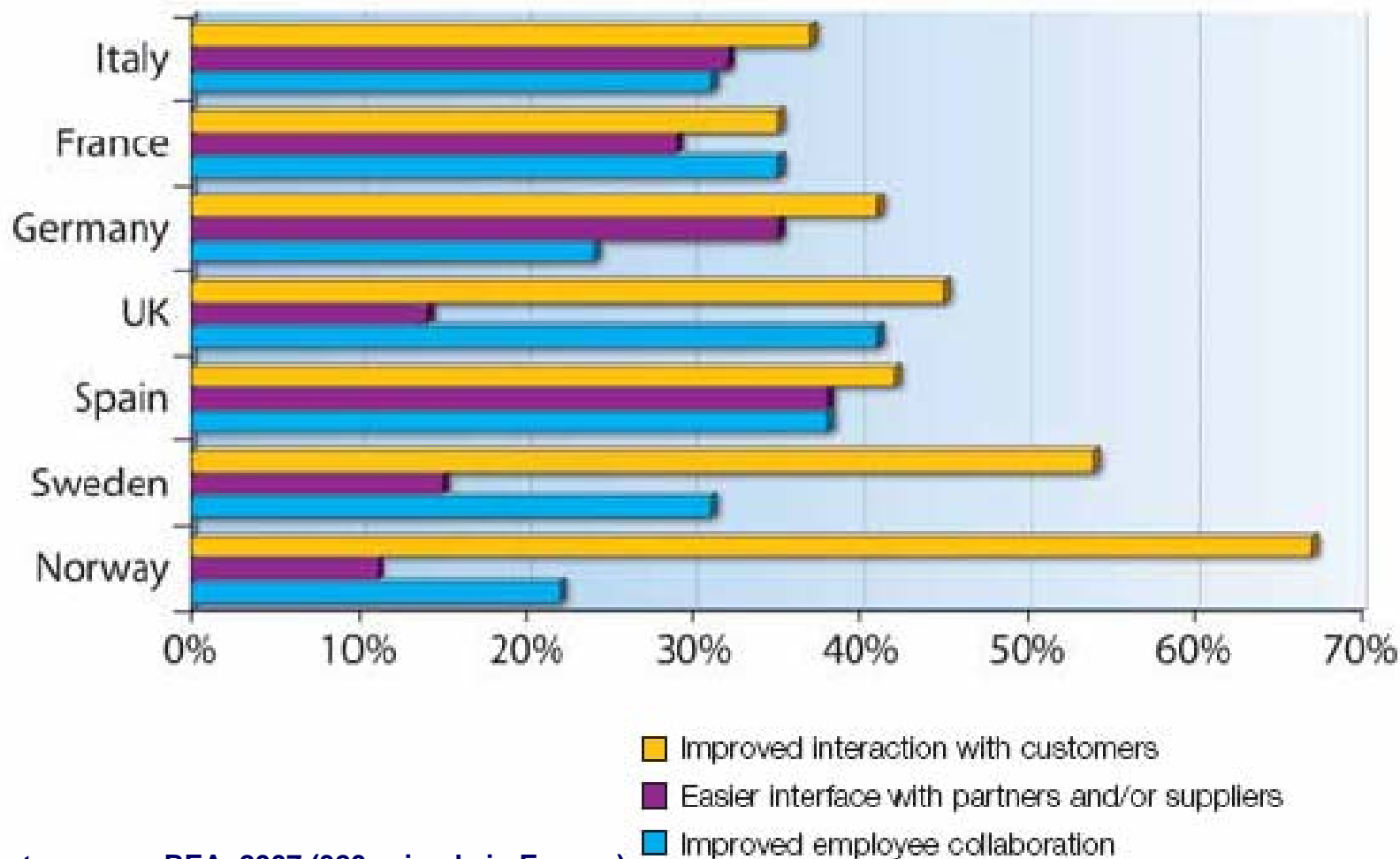

Fonte: survey BEA, 2007 (320 aziende in Europa)

# L'economia della collaborazione

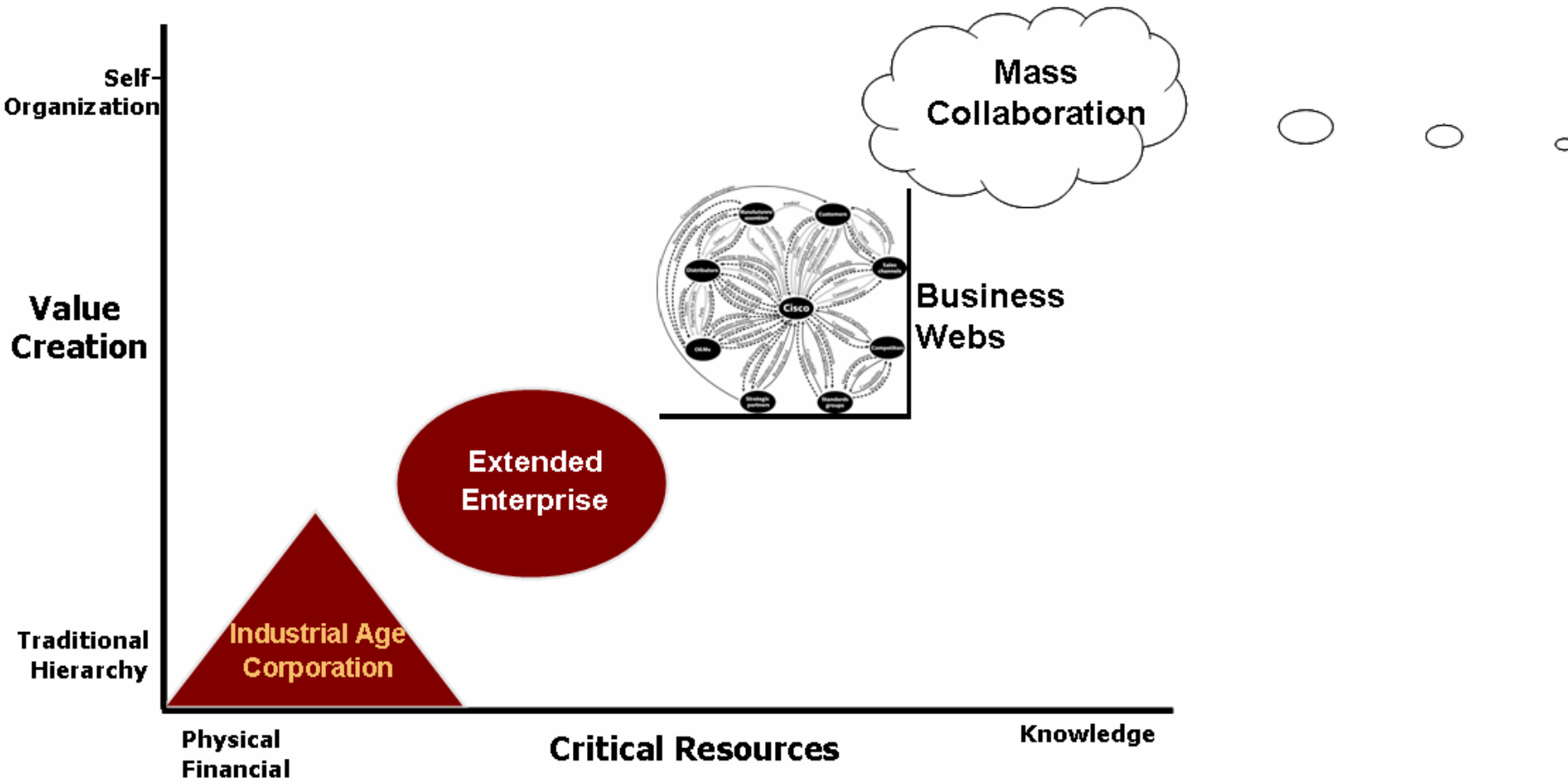

Fonte: New Paradigm Learning Corporation 2006

# Il Cooperative Working: alcuni esempi

## Cooperative Production



- **The Peer Produced Airplane**
- In the past, Boeing wrote detailed specifications for each part and asked suppliers to build to plan
- Today, suppliers co-design airplanes from scratch and deliver complete sub-assemblies to Boeing's factory, where a single plane can be snapped together like Lego blocks, in as little as 3 days

## Cooperative R&D

- Release over internet of all research raw data on genetic basis of type 2 diabetes
- Data considered as first step in developing collaborative process with universities and research centers to identify and develop drugs

## Cooperative Marketing/Sales

### Wiki degli utenti

Enciclopedia fatta da utenti che sono ripagati con punti dei programmi di Loyalty e premi

### Blog degli utenti

Utilizzato per far risolvere problematiche tecniche senza intervento dell'operatore e far emergere idee ed esigenze insoddisfatte

### Marketing interattivo

- Segmentazione on-line
- Condivisione idee
- Sviluppo prodotto

Fonte: NetConsulting su varie fonti, 2007

# Le nuove relazioni tra azienda e lavoratore

Web 1.0



- Spazio
- Orari di lavoro
- Gerarchia
- Appartenenza



Web 2.0

Processi aziendali

Know how in rete

Sistemi Informativi

Social Networking

Mobility

Collaborazione



Fonte: NetConsulting



# Web 2.0 nelle aziende: un primo assessment

% rispondenti

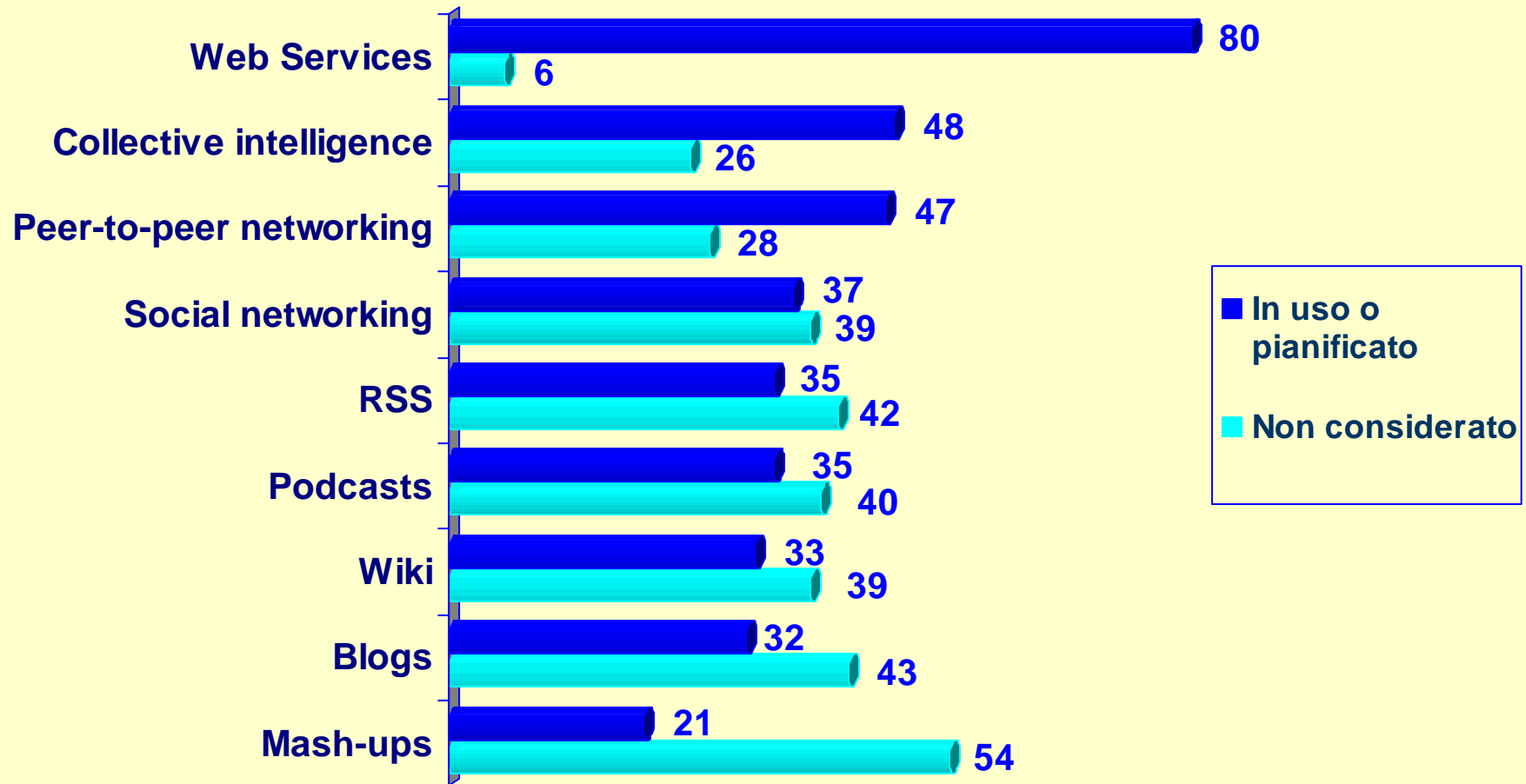

Fonte: McKinsey Survey, 2007 (2.580 aziende worldwide)



# Le implicazioni

# 1° Il cambiamento del paradigma organizzativo

Da

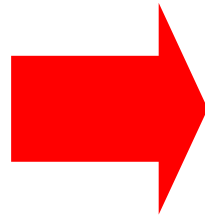
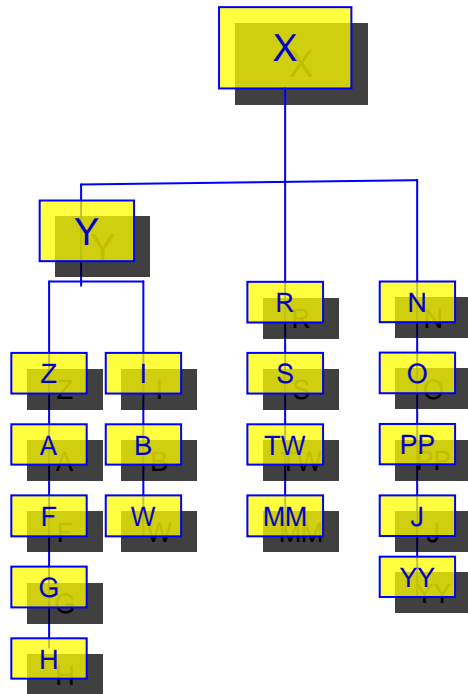

A

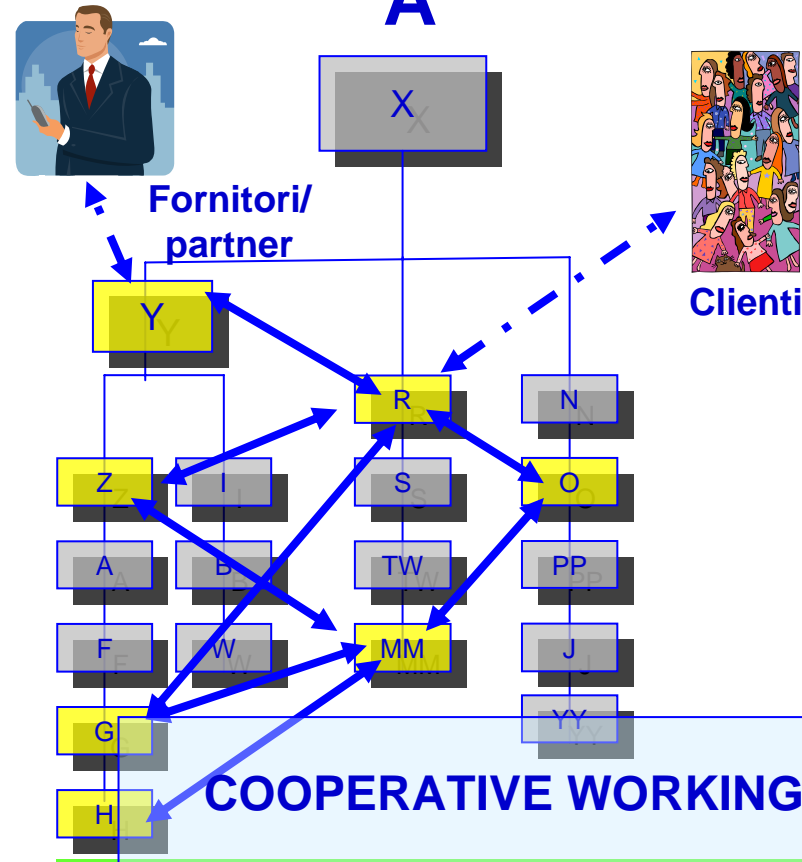

- Conoscenza accentrata
- Reti formali di comunicazione
- Organizzazione gerarchica
- Difficoltà a gestire processi trasversali

- Conoscenza condivisa
- Reti informali di comunicazione e basate sull'utilizzo di strumenti tecnologici
- Organizzazione flessibile e "process driven"

## 2° Processi e reti informali

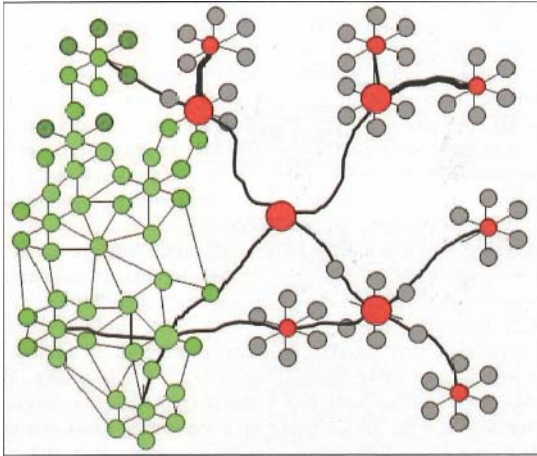

Fonte: NetConsulting, 2007

Processi target

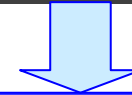

Risorse chiave

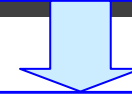

Reti informali e ruoli

“Formalizzare” le reti informali:

- Leadership
- Obiettivi
- Criteri di valutazione
- Incentivi
- Tecnologie



# 3° La profilazione degli utenti

## Ruolo nel processo/ Fabbisogno informativo

- Attività svolta all'interno del processo
- Livello di interazione con interfacce esterne all'azienda
- Tipologia di documenti/ contenuti e flussi di comunicazione gestiti
- Tempi di risposta richiesti

Mobilità

Mobilità

- Nessuna mobilità
- All'interno della sede
- Tra differenti sedi
- Home workers
- Presso clienti-fornitori
- Full-mobile worker

Utilizzo tecnologie

Utilizzo tecnologie

- Tradizionali
- Sperimentatori
- Utenti avanzati
- Utenti 2.0 (stessi strumenti tecnologici anche in contesti extralavorativi)

Ruolo nel processo/  
Fabbisogno informativo



...e le tecnologia?

# La crescente complessità nei sistemi di comunicazione delle aziende

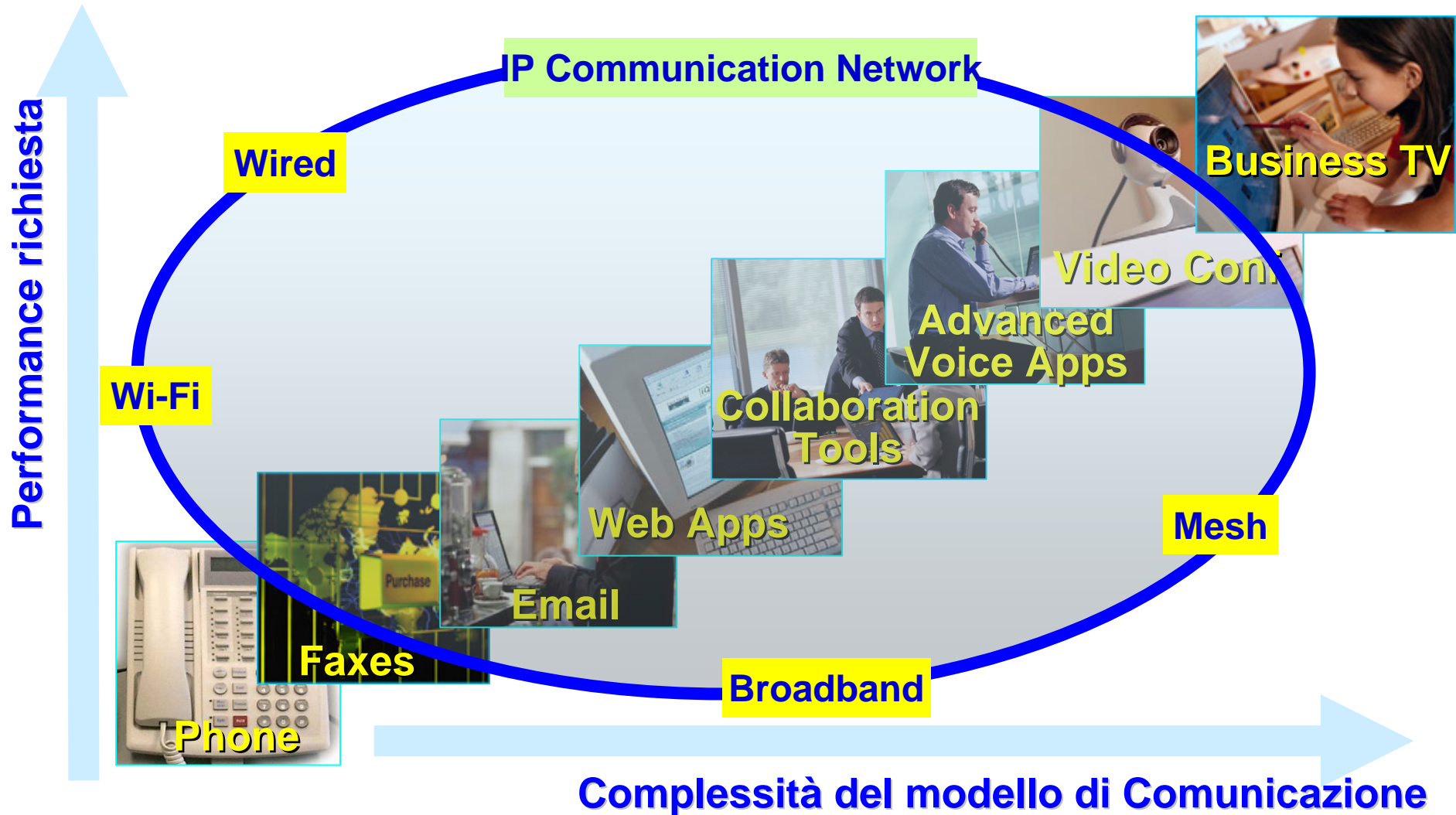

# I requisiti di un'architettura di Cooperative Working

Scalabilità

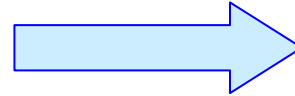

- Web scale
- On demand

Sicurezza

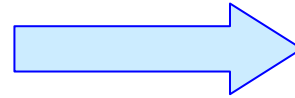

- Comunicazioni
- Identity Management
- Federated access

Storage

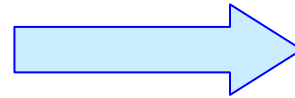

- Testo, immagini, video, audio,...
- Oggetti, sessioni, sistema

Ricerca

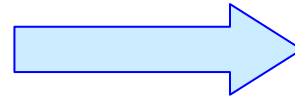

- Ricerca full-text

Facilità d'uso

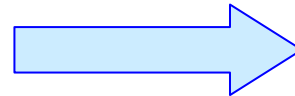

- Click and go
- No plug-ins required



# Ricerca un approccio globale alla “Comunicazione”

**PABX**  
centrica

“Office”  
centrica

“Communication”  
centrica

**VS**



# Videocomunicazione: tecnologia e “human touch”



## Vantaggi

- Time-to-market
- Riduzione costi e tempi
- Interattività, naturalezza ed efficacia comunicazione



### “HUMAN TOUCH”

- Condivisione risorse critiche (“esperti”)
- Immagine aziendale
- Miglioramento rapporti con interlocutori esterni (fornitori, clienti, partner)

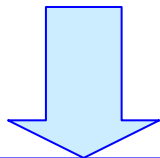

## Stimoli



- Disponibilità di banda
- Flessibilità e facilità nell’accesso al servizio
- Gestione videocomunicazione in mobilità

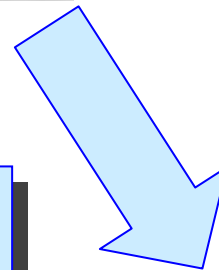

## Utilizzi

- Telemedicina
- Progettazione e sviluppo prodotto
- Monitoraggio processi produttivi e operations
- Formazione
- Processi di vendita ed assistenza con intervento di “esperti”

# In sintesi...

## Quali strumenti per:

Technology	Internal	External
<b>Blog</b>	Internal project updates Configuration updates	Project updates Organization updates Notification of changes
<b>Wiki</b>	Project documentation Technical documentation FAQ/knowledge base Contract drafting Presentation development	FAQ/knowledgebase (Wikipedia, LyricWiki)
<b>RSS feeds</b>	Sales leads To-do lists Lightweight integration with other systems and tools	Blog, wiki updates Repurpose data from other systems and tools
<b>Instant messaging</b>	Bring in additional assistance for sales Technical Support calls	Realtime updates, transactions
<b>Calendaring</b>	Schedule meetings View availability Schedule resources	Schedule meetings Synchronize calendars
<b>Webconferencing</b>	Training Presentations to staff	Product demos Presentations to clients
<b>Desktop sharing</b>	Training Technical Support	Product demos Technical Support
<b>Presencing</b>	Availability for collaboration using other methods such as phone, in-person	Availability for collaboration using other methods such as phone, in-person
<b>Shared workspaces</b>	Project documentation Research resources and references Document sharing	Product/service development and testing Document sharing
<b>Chat rooms</b>	Virtual meeting	Virtual meeting
<b>Discussion forums/ bulletin boards</b>	Threaded discussion on particular topics	Comments or suggestions list

Fone: NetConsulting su AIIM, 2007

## Quali processi



## Quali utenti



## Quali contenuti



## Quali device



## Per quale risultato...

- Anytime, anywhere, any device
- Qualità videocomunicazione
- Allineamento e flessibilità rispetto al business

Per l'economia della collaborazione...  
e un'Italia 2.0!

**GRAZIE**  
***diruscio@netconsulting.it***